

One Source

# KREBS® millMAX™ Pumps



**The ORIGINAL suction side sealing pump**

**FLSMIDTH**  
**KREBS**

# millMAX™ pumps technology

## millMAX solves this kind of problem



Competitor's suction liner and impeller - 550 hours



millMAX™ after 1500 hours of wear

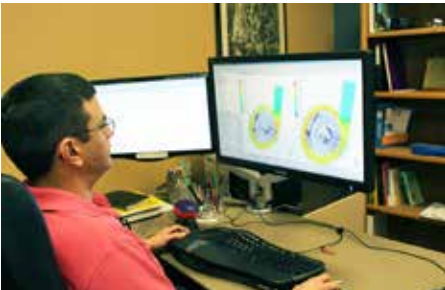

We use the latest simulation software technology for design and performance testing of our millMAX™ pumps.

The millMAX™ Pump has a unique patented design developed exclusively for mill discharge duties and adapted for other severe abrasive slurries. The same wet end components can be offered as a conversion kit to existing pumps, without the need to disturb the foundation or existing bearing frame assembly.

The millMAX Pump features a patented on-line wear clearance adjustment, which minimizes the cost per ton pumped compared to conventional hard metal and rubber lined slurry pumps through:

- Increased wear life
- Even wear life of all wet end parts
- Less down time
- Lower power consumption
- Increased mill throughput
- More consistent cyclone separation
- Improved gland seal performance
- Low-cost — no risk wet end replacement

### The Heart of the Design

The patented on-line suction side wear clearance adjustment permits the initial clearances to be maintained throughout the life of the pump. This extends the life of the impeller and suction wear faces to near, or equal that of, the casing for a one time maintenance rebuild.

The reduction of solids grinding between the impeller and suction side reduces power consumption and wear. The millMAX™ Hybrid Suction Sealing System maintains constant flow and pressure, without increasing speed or the danger of motor overload.

Krebs millMAX Pumps treat the cause of pump wear and loss of efficiency, whereas competitive pumps treat the symptoms through materials or predictive uneven wear rates.

### millMAX™ Hybrid Suction Sealing System

Tight clearances between the backliner and impeller ensures that shaft sealing system works well.

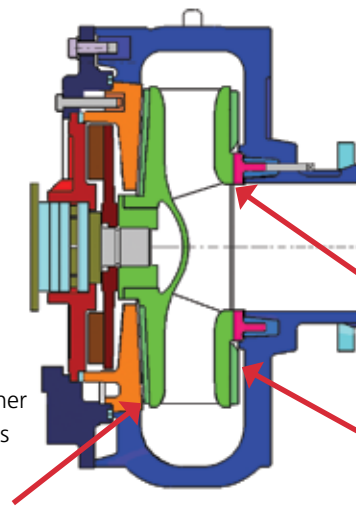

Tight clearances at the wear ring prevents suction-side recirculation.

Wide clearances at expelling vanes prevents large solids from being crushed.

# millMAX™ pumps

In most established millMAX™ installations, wear life of parts has been even and in the majority, overall wear life has generally improved by 50% to 100%. This increase in wear life is achieved together with a reduction in power, generally in the 10% to 20% or lower range.

The reduction in power can then be taken as a cost savings, or through additional pumping capacity with the same installed motor.

With the millMAX™ Hybrid Suction Sealing System, the front clearance is adjusted while the pump is running, and takes only five minutes to perform. This clearance is adjusted normally six to eight times throughout the life of the wet end parts.

## Wet End Conversions

The Krebs millMAX™ Pump is a new design, hard metal pump and wet end conversion kit, designed exclusively for mill discharge and other abrasive slurries. The Krebs millMAX™ Pump adapts to a variety of power frames without disturbing the foundation or bearing frame assemblies.

The millMAX™ design can be applied to an existing pump through a wet end conversion kit, including impeller, casing, backliner, and gland seal.

The millMAX™ conversion kit is supplied with an adapter ring, seals, and all hardware to adapt to a variety of power frames. This achieves the same results as a complete pump — on a maintenance budget.



24 x 20 - Chile - Copper



10x8 - US - Coal



16x14 - Zambia - Copper



20x18-43 - Australia - Gold



14x12 - US - Iron Ore

# Technical - Specifications

## The Krebs millMAX™ pump design includes the following:

**Casing** - designed for minimum slurry turbulence and even wear. Includes integral wear ring, carrier, and adjustment screws for on-line adjustment and elimination of suction side recirculation.

**Wear Ring** - adjustable wear ring assembly to permit closing of suction side impeller clearance during operation.

**Impeller** - designed for high slurry efficiency and hydraulic performance. Machined surface at the eye for wear ring adjustment and high expelling vanes.

**Suction Liner** - with integral wear ring (14x12 and larger). Matching full impeller diameter and profile for close operating clearance.

**Wear Parts** - designed hydraulically to wear evenly. Constructed of high chrome at 650/720 Brinell hardness.

**Power Frame** - heavy duty cast iron pedestal with external bearing assembly adjustment mechanism. Drilled for overhead motor mounting assembly.

**Flanges** - loose intake and discharge flanges drilled to suit various pipe requirements.

**Bearing Assembly** - heavy duty shaft and indirect fitted taper roller bearings rated at 100,000 hrs B-10 life minimum.

### millMAX™ Power Frame

- Heavy duty cast pedestal
- External bearing assembly adjustment
- Wide bearing centers
- Heavy duty shaft and bearings.
- Double clamp

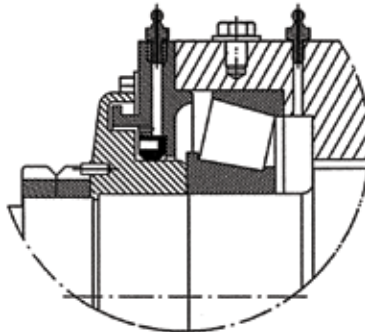

### Reverse Taper Roller Bearings

- Increases effective load span to improve life
- Main bearing failure is due to under greasing
- Pumping action of taper rollers discharges grease to the outside, preventing ingress of slurry

### Water Flush Gland

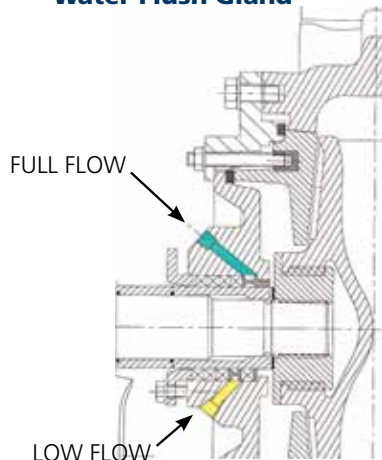

### High Performance Centrifugal Dry Gland Seal

- Large expeller diameter generates high suction level sealing capacity
- Zero leakage while operating

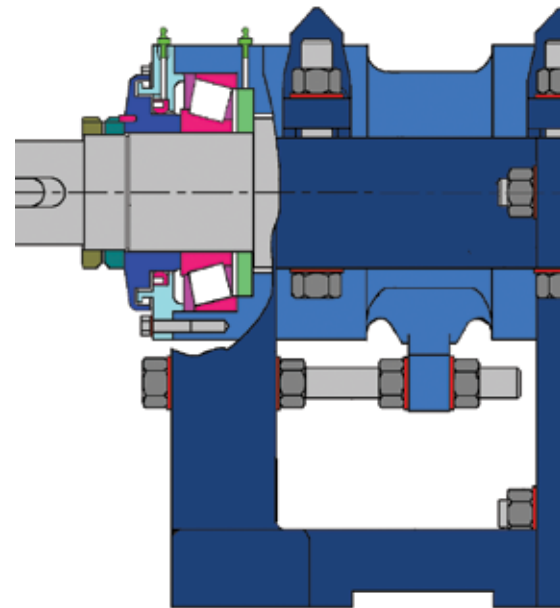

### Maximum expected flow rate into a water flush seal at 10 psig (68.9 kPa) above pump discharge pressure

Power Frame	Full Flow (gpm)	Full Flow (m <sup>3</sup> /h)	Low Flow (gpm)	Low Flow (m <sup>3</sup> /h)
MMAA	8.0	1.8	1.0	0.2
MMA	15.0	3.4	2.0	0.5
MMB	20.0	4.5	3.0	0.7
MMC	25.0	5.7	4.0	0.9
MMD	30.0	6.8	5.0	1.1
MME	55.0	12.5	N/A	N/A
MMF	85.0	19.3	N/A	N/A

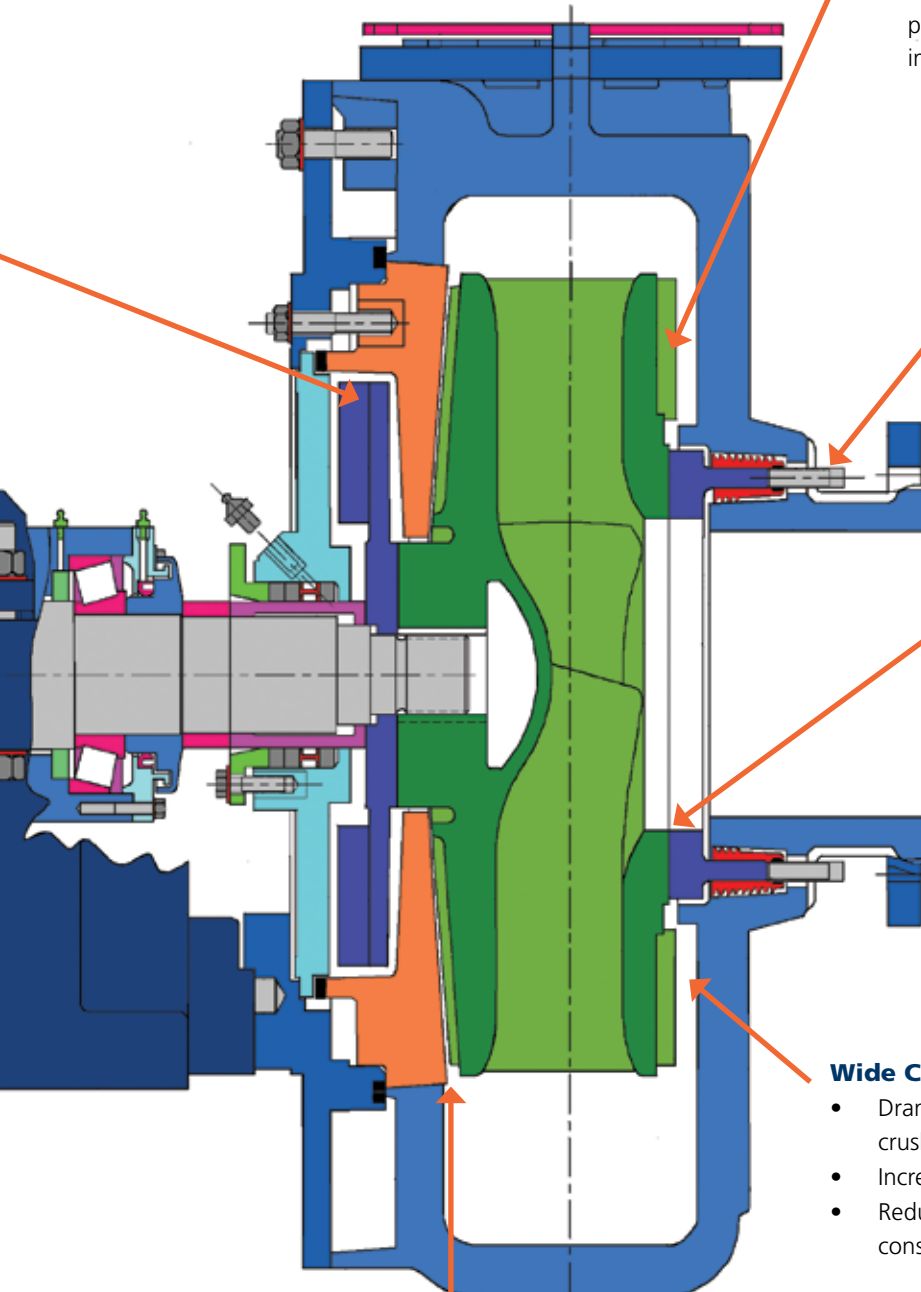

**High Radial Vanes**

- Clears large solids
- Prevents solids from being crushed
- Reduces casing slurry pressure at the eye of the impeller



**External Wear Adjustment Screw**

- Four screws for on-line wear clearance adjustment
- Adjusted while the pump is operating
- Adjusted six to eight times during the life of the wet end of the pump



**Adjustable Wear Ring**

- Wear ring takes up clearance at the impeller
- Adjusted during operation
- Reduces suction side recirculation
- Maintains hydraulic performance

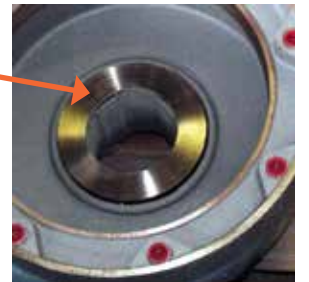

**Wide Clearance**

- Dramatic reduction in crushing of solids
- Increased wear life
- Reduced power consumption

**Narrow Clearance**

Reduces pressure at gland to assist centrifugal dry gland seal or reduce gland water pressure.

**driMAX™ Mechanical Seal**

- Operates in extreme abrasive environment
- Clearance adjustment can be made without moving seal

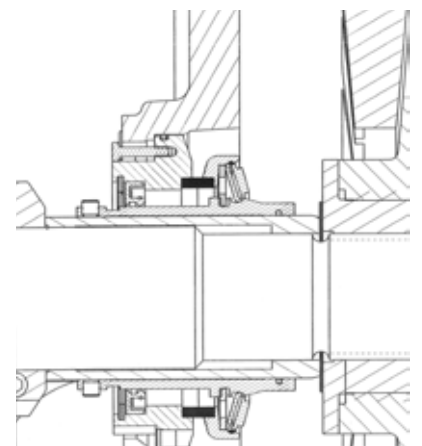

# millMAX engineering dimensions

## Standard millMAX discharge positions

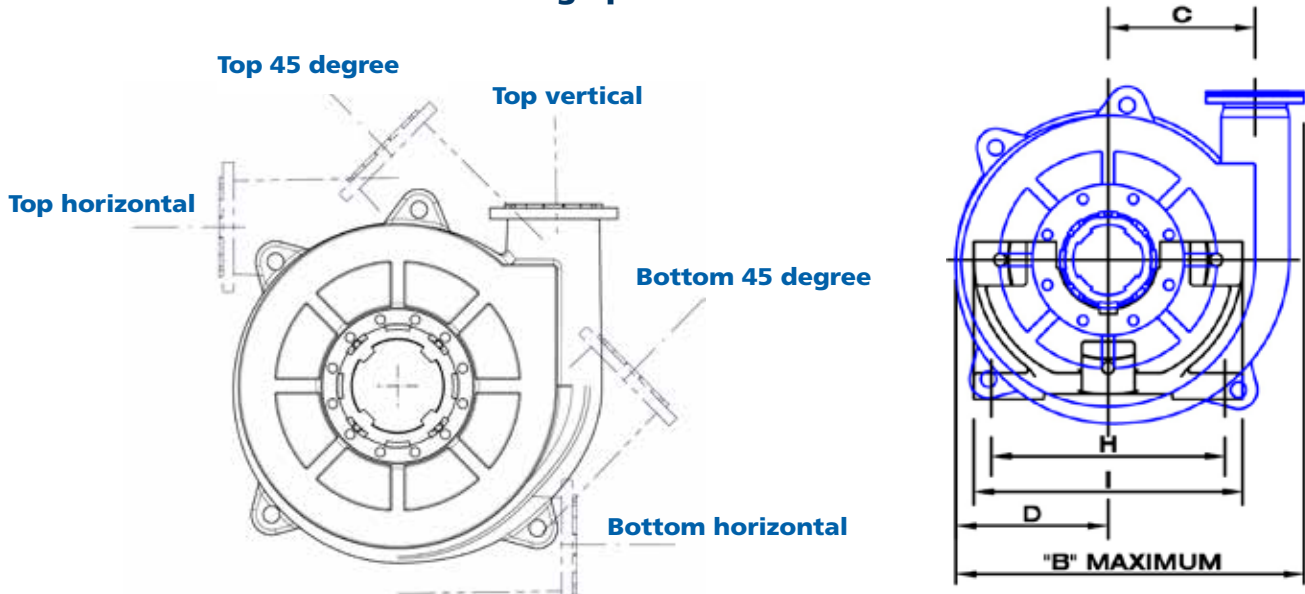

Pump Model	Size	Frame	A	B	C	D	E	F	F1	G	G1	H	I	J	K
MM080AA4	3X2	MMAA	794	403	138	185	185	200	31	150	110	314	370	42	115
MM100AA4	4X3	MMAA	870	514	185	234	262	200	35	188	148	314	370	42	115
MM100A4	4X3	MMA	974	514	185	234	262	230	5	188	148	375	431	65	150
MM150A4	6X4	MMA	1020	629	229	285	326	230	55	219	190	375	431	65	150
MM150B4	6X4	MMB	1244	629	229	285	326	300	15	219	190	475	548	80	215
MM200B4	8X6	MMB	1342	998	419	436	480	300	169	290	277	475	548	80	215
MM200C4	8X6	MMC	1491	998	419	436	480	400	69	290	277	666	766	100	227
MM250B4	10X8	MMB	1394	1032	419	442	480	300	168	325	290	475	548	80	215
MM250C4	10X8	MMC	1540	1032	419	442	480	400	68	325	290	666	766	100	227
MM300C4	12X10	MMC	1574	1235	462	570	610	400	198	342	348	666	766	100	227
MM300D4	12X10	MMD	1933	1235	462	570	610	500	98	342	348	863	963	150	349
MM350C4	14X12	MMC	1757	1513	559	687	750	400	314	402	178	666	766	100	263
MM350D4	14X12	MMD	2034	1513	559	687	750	500	214	402	178	863	963	150	349
MM400C4	16X14	MMC	1835	1737	666	804	893	400	426	441	229	666	766	100	263
MM400D4	16X14	MMD	2112	1737	666	804	893	500	326	441	229	863	963	150	349
MM450D4	18x16	MMD	2176	1933	708	908	950	500	452	486	200	863	963	150	349
MM450E4	18X16	MME	2330	1933	708	908	950	850	102	486	200	1022	1111	150	321
MM500D4	20X18	MMD	2224	2032	703	1011	1054	500	515	506	245	863	963	150	349
MM500E4	20X18	MME	2380	2032	703	1011	1054	850	165	506	245	1022	1111	150	321
MM600E5	24X20	MME	2446	2208	791	1030	1226	850	218	565	236	1022	1111	150	321
MM600F5	24X20	MMF	2880	2208	791	1030	1226	1092	24	565	236	1422	1549	190	286
MM700F5	28X26	MMF	3017	2748	1060	1253	1300	1092	235	648	304	1422	1549	190	286

# Bare shaft pump

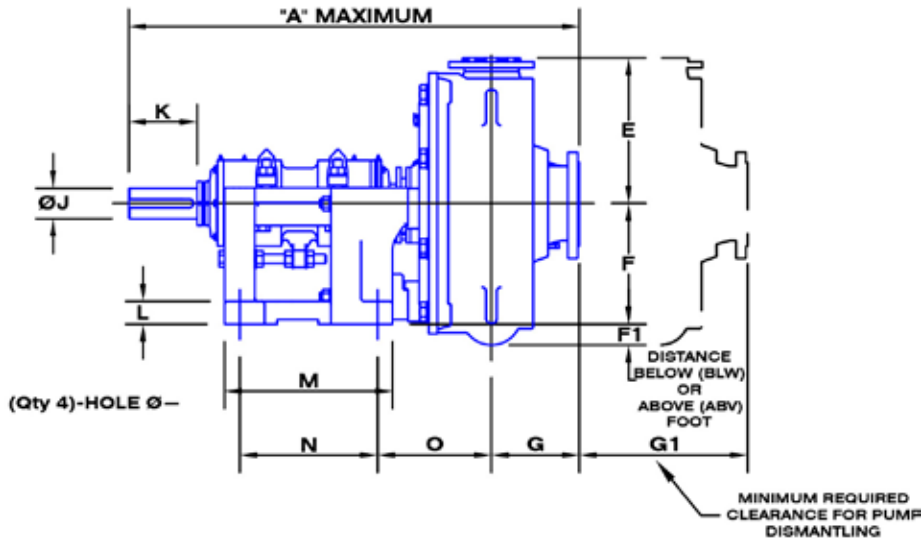

## Drive arrangements



Reverse overhead



Inline with gearbox



Direct drive



Side by side

Key	L	M	N	O	Hole Dia.	Weight	Pump Model
8X12X100	30	293	235	210	19	182	MM080AA4
8X12X100	30	293	235	247	19	301	MM100AA4
11X18X100	40	323	265	278	22	369	MM100A4
11X18X100	40	323	265	279	22	526	MM150A4
14X22X150	50	410	335	339	29	689	MM150B4
14X22X150	50	410	335	370	29	1496	MM200B4
16X28X180	75	555	455	370	35	1897	MM200C4
14X22X150	50	410	335	384	29	1550	MM250B4
16X28X180	75	555	455	384	35	1952	MM250C4
16X28X180	75	555	455	413	35	2727	MM300C4
36X20X280	78	693	593	487	41	3535	MM300D4
16X28X180	75	555	455	493	35	4396	MM350C4
36X20X280	78	693	593	514	41	5114	MM350D4
16X28X180	75	555	455	532	35	4999	MM400C4
36X20X280	78	693	593	567	41	5754	MM400D4
36X20X280	78	693	593	589	41	8655	MM450D4
36X20X280	38	1048	700	515	32	9314	MM450E4
36X20X280	78	693	593	619	41	10032	MM500D4
36X20X280	38	1048	700	545	32	10732	MM500E4
36X20X280	38	1048	700	555	32	12587	MM600E5
45X25X254	38	1451	1218	534	38	15919	MM600F5
45X25X254	38	1451	1218	583	38	21803	MM700F5

# KREBS® milMAX™ Pumps

www.flsmidthkrebs.com

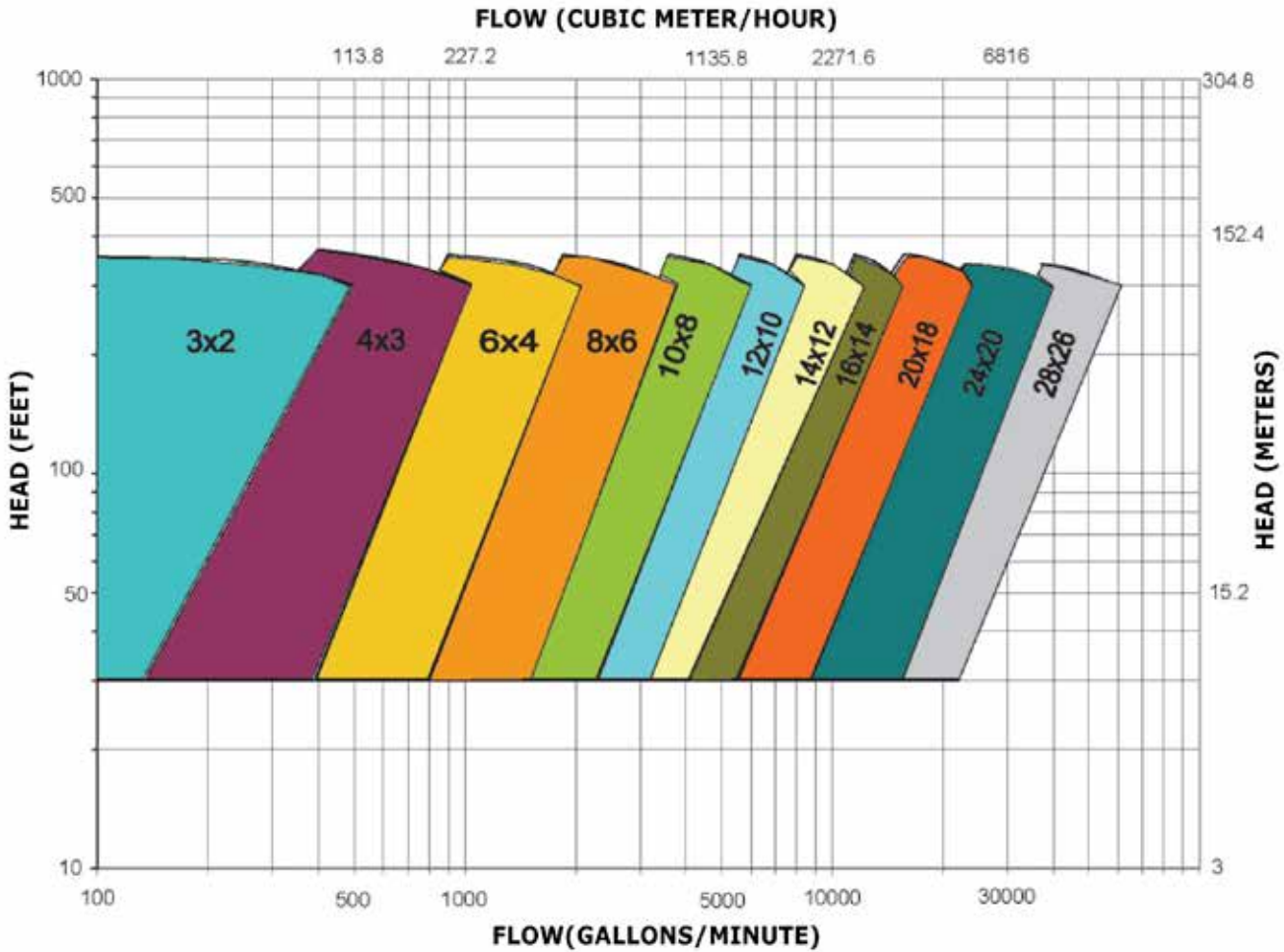

## World-class Service

The Krebs' customer service philosophy is to consistently exceed the expectations of our customers when it comes to providing technical support, processing orders and maintaining parts availability. Starting with the sales process, and extending throughout the life of the supplied process solution, we strive to provide an unmatched, world-class customer experience.

**Tucson, Arizona USA**  
Tel: +1 520 744 8200  
E-mail: [krebs@flsmidth.com](mailto:krebs@flsmidth.com)

**Neusiedl am See, Austria**  
Tel: +43 2167 3345  
[krebseurope@flsmidth.com](mailto:krebseurope@flsmidth.com)

**Beijing P.R. China**  
Tel: +86-10 8468 9100  
[krebschina@flsmidth.com](mailto:krebschina@flsmidth.com)

**Johannesburg, South Africa**  
Tel: +27 (0)10 210 4750  
[krebsafrica@flsmidth.com](mailto:krebsafrica@flsmidth.com)

**Queensland, Australia**  
Tel: +61 7 5519 5700  
[krebsaustralia@flsmidth.com](mailto:krebsaustralia@flsmidth.com)

**Sao Paulo, Brasil**  
Tel: +55-15-3416-7400  
[krebsbrasil@flsmidth.com](mailto:krebsbrasil@flsmidth.com)

**Chennai, India**  
Tel: +91 44 4748 1000  
[krebsindia@flsmidth.com](mailto:krebsindia@flsmidth.com)

[www.flsmidthkrebs.com](http://www.flsmidthkrebs.com)

**Western Australia**  
Tel: +61 8 6258 4800  
[krebsaustralia@flsmidth.com](mailto:krebsaustralia@flsmidth.com)

**Santiago, Chile**  
Tel: +56 2 2463 8350  
[krebschile@flsmidth.com](mailto:krebschile@flsmidth.com)

**Manila, Philippines**  
Tel: +63-2-687-9251  
[Krebs-Philippines@flsmidth.com](mailto:Krebs-Philippines@flsmidth.com)

